



OPERATOR'S INSTRUCTION MANUAL

MODEL : **861 000** _____

ENGINE MODEL : _____

SERIAL : _____

ENGINE SERIAL : _____

DATE OF PURCHASE : _____

PURCHASED FROM : _____



⚠️ WARNING ⚠️

THIS PRODUCT IS DESIGNED AND MANUFACTURED TO PROVIDE SAFE AND DEPENDABLE SERVICE IF OPERATED ACCORDING TO INSTRUCTIONS. THE MANUFACTURER PROVIDES THE FOLLOWING INSTRUCTIONS FOR USE AND CARE OF THIS EQUIPMENT AND RELIES UPON THE PURCHASER TO SEE TO IT THAT THESE INSTRUCTIONS ARE MADE CLEAR TO THE PERSONS WHO WILL ACTUALLY BE USING THE EQUIPMENT. FAILURE TO DO SO COULD RESULT IN SERIOUS INJURY OR EQUIPMENT DAMAGE.



INDEX

DEFINITIONS	4
INTRODUCTION	5
APPLICATION	5
RESTRICTIONS	5
FALL ARREST MODE:	7
A FALL-RESTRICTING SYSTEM	8
A FALL-ARREST SYSTEM	8
USE	9
PRELIMINARY VERIFICATION	9
CALCULATIONS	9
POSITIONING ON THE ROOF	10
TRAINING	12
INSPECTION, MAINTENANCE, STORAGE	12
INSPECTION	12
MAINTENANCE	12
STORAGE	12
LIFTING	13
STICKERS	14
PRE-USE AND INSPECTION FORM FOR GRIZZLY 861 000 HERCULES MOBILE ANCHORING SYSTEM	15



861 000 HERCULES MOBILE ANCHORING SYSTEM

Thank you for purchasing this quality GRIZZLY product. With proper use and care, the Hercules Mobile Anchoring System will provide many years of reliable service. For the safety of all job-site personnel it is mandatory that the instructions provided for the use and handling of the equipment be read and thoroughly understood by the operators. All workers that use any type of fall protection equipment need to be fully trained with both written and verbal instruction by competent and/or qualified person in accordance with the applicable Health and Safety Legislation and Regulations in their Province or State. This information can be found in Canada in the Canada Labour Code, Provincial Regulations and The Canadian Standards Association (CSA) in the United States under OSHA and the ANSI Standards. All Provinces and States have specific training requirements for all users of fall protection equipment. This manual is to be used as a tool for training and in no way replaces training of workers by qualified persons



CAUTION

INTENDED USE; THIS MACHINE IS INTENDED TO BE USED ON A FLAT SURFACE SUCH AS A FLAT ROOF OR FLAT, LEVEL GROUND. ABUSE AND OR MODIFICATION OF THIS EQUIPMENT VOIDS THE MANUFACTURER'S WARRANTY AND IS THE SOLE RESPONSIBILITY OF THE OWNER/USER, SHOULD ANY DAMAGE OR INJURY OCCUR.



DEFINITIONS

The following definitions apply to the present manual:

Fall Arrest System: An assembly of components that, when properly assembled and used together and when connected to a suitable anchorage, will arrest a workers fall

Note: a system designed solely for travel restraint or work positioning typically will not meet the requirements for fall arrest (Definition as per CSA)

Travel restraint: An assembly of components that, when properly assembled and used together and when connected to a suitable anchorage, prevents a worker from reaching an unprotected edge or opening where a fall could occur (Definition as per CSA)

Worker; for the purpose of this manual is any person that is protected by falling by using either a work positioning system, travel restraint, fall restricting or who may fall while using a fall arrest system. (Definition as per CSA Z259.11-05)

For the purpose of this manual a competent worker is considered:

“competent worker”, in relation to specific work, means a worker who,

- is qualified because of knowledge, training and experience to perform the work,
- is familiar with Applicable Health and Safety Legislation and with the provisions of the regulations that apply to the work, and
- has knowledge of all potential or actual danger to health or safety in the work;

User: Person that has received the necessary training to be authorized to use the equipment involved in the training.

The definition of a competent person and/or a qualified person can change between Provinces and Countries some examples are below:

Ontario

“competent person” means a person who,

- (a) is qualified because of knowledge, training and experience to organize the work and its performance,
- (b) is familiar with this Act and the regulations that apply to the work, and
- (c) has knowledge of any potential or actual danger to health or safety in the workplace; (“competent person”)

Some OSHA (USA) and ANSI (American National Standards Institute) documents define a competent person as follows

Competent Person: One who is capable of identifying existing and predictable hazards in the surroundings or working conditions which are unsanitary, hazardous, or dangerous to employees, and who has authorization to take prompt corrective measures to eliminate them.

Generally a Competent person is someone with experience and knowledge enough to understand all the hazards that may be involved with the work and how to effectively control them. They should also have a good working knowledge of the particular laws pertaining to the work as well as the regulations and the CSA, ANSI or other recognised standards that pertain to the work and equipment.



INTRODUCTION

APPLICATION

The GRIZZLY HERCULES is a Mobile Anchoring System for fall protection that when used correctly and according to the directions in this manual and in compliance with all the regulations and standards, (These may change from Province to Province or State to State); will afford adequate fall protection for workers while working on flat roofs and similar structures.

NOTE:

All Provinces and States have specific training requirements for all users of fall protection equipment. This manual is to be used as a tool for training and in no way replaces training of workers by qualified persons

RESTRICTIONS

NOT FOLLOWING THE RULES OUTLINED FOR THE USE OF the GRIZZLY HERCULES Mobile Anchoring System may lead to serious injury or death.

In order to ensure the efficiency of the HERCULES Mobile Anchoring System, the following guidelines must be respected:

1. Minimum Safe Distance Required, A competent person must ensure that the system is set up in such a way that considering the distance of the fall, the HERCULES Mobile Anchoring System will only be used in fall arrest mode on roofs or structures with enough minimum safe distance from the ground or a lower level to prevent the worker from falling far enough to hit the ground or the lower level. There should be at least a 3 foot margin of safety added to the fall distance calculations. A Competent Person must always do the necessary calculations to ensure that the minimum height restrictions are adhered too. Note: There are different limits to the amount of free fall allowed in some jurisdictions. There are a number of ways to calculate this distance including a "Splat Bag" or other equipment available from fall protection equipment suppliers or by calculating the distance taking into account the length of the lanyard and shock absorber - one of these calculations is described in (See fig. 1)

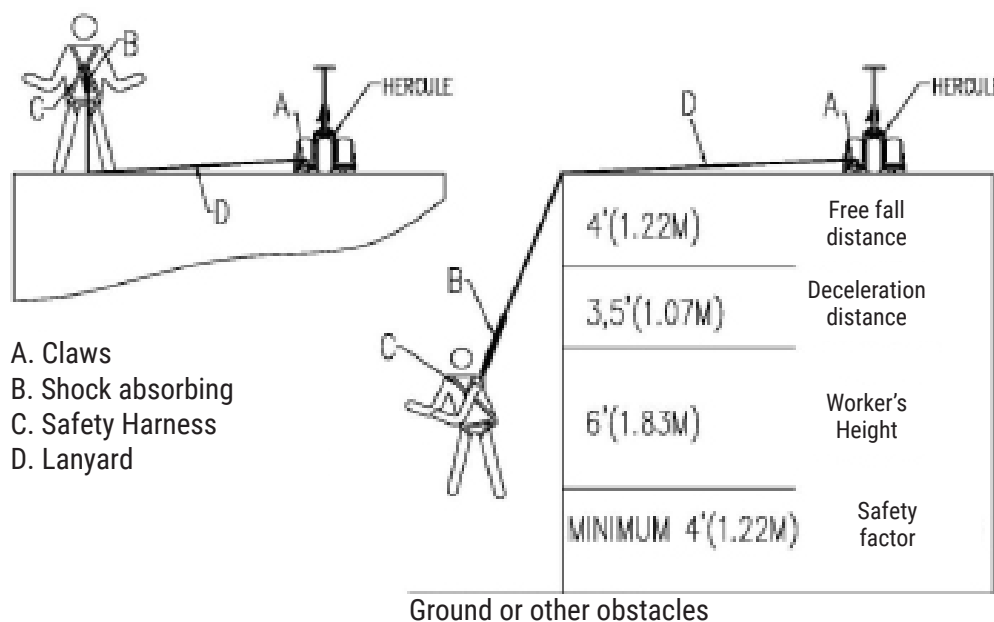

Fig. 1



2. **Horizontal lifeline:** The HERCULES Mobile Anchoring System is not designed to be used as part of a horizontal lifeline system and shall not be used for that purpose.
3. **Number of simultaneous users:** the maximum number of users that may be secured to the HERCULES Mobile Anchoring System varies in accordance with the mode used :
 - In travel restraint mode : 4 workers (limit of one worker per anchorage)
 - or
 - In fall arrest mode : 2 workers (limit of one worker per pivot arm)

ONTARIO, EFFECTIVE JUNE 2017

- In fall arrest mode, a mobile anchor system could only be used for ONE worker;
- In travel restraint mode, a mobile anchor system could only be used for up to TWO workers;
- Units sold or distributed for use in the Province of Ontario should have no more than two attachment points utilized at any given time;

PLEASE CHECK YOUR PROVINCE'S OR STATE'S REGULATIONS BEFORE USE

4. **Roof types:** The HERCULES Mobile Anchoring System cannot be used on a sloped roof. The mobile anchoring system must only be used on the following types of roofs:
 - Built-up asphalt and gravel
 - Modified bitumen system
 - Single-ply system such as fully adhered TPO, PVC, EPDM
 - Wood (deck), mechanically fixed plywood
 - Metal (deck) of at least 22 gage and at most 20 gage
 - For use on any other types of roofs, inquire with Alcor before using.
5. **Roof state:** Before setting up the HERCULES Mobile Anchoring System on a roof, the user must make sure that the roof must be structurally sound and of sufficient strength to support the HERCULES Mobile Anchoring System + the weight of the users and their tools.
6. The HERCULES Mobile Anchoring System must not be set up on water, frost, snow, ice, oil, grease or any other substance that could decrease the adherence of HERCULES Mobile Anchoring on the roof.
7. **Safety equipment required for the use of the HERCULES Mobile Anchoring System:** Depending on the mode chosen, each user must use the following equipment:



Travel restraint mode:

Two methods of travel restraint can be used

- 1) Connecting an adequately anchored lifeline directly to the D-ring of the worker's full body harness. It is critical that the length of the lifeline, measured from the anchor point, is short enough to restrain the worker from any fall hazard.
- 2) Attaching a lanyard from the D-ring of the worker's full body harness to a rope grab on a lifeline. There must be some means, such as a knot in the lifeline, to prevent the rope grab from sliding along the lifeline to a point where the worker is no longer restrained from falling.

It is recommended to keep the worker at least 1 foot back from the fall hazard (See fig. 2)

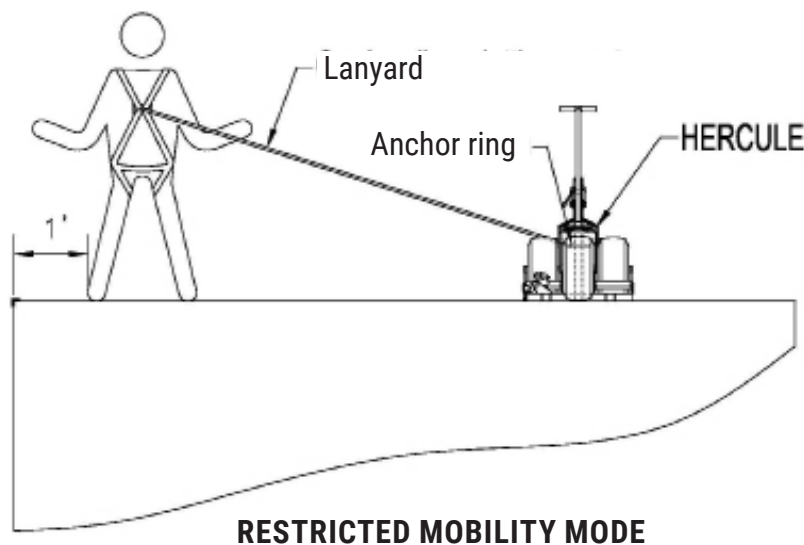

Fig. 2

FALL ARREST MODE:

If workers cannot be protected from falls by guardrails or travel restraint, they can be protected by one of the following methods:

- fall-restricting system
- fall-arrest system.

In the event of a fall, these systems must keep a worker from hitting the ground, the next level below, or any other objects below.



A FALL-RESTRICTING SYSTEM

A fall-restricting system is designed to limit a worker's free fall distance to less than 0.6 metres (2 feet). One method to comply with this is to use a Self Retracting Lanyard that is set up to adequately limit a workers fall distance. Self Retracting Lanyards should be used with a CSA approved personal shock absorber, CSA Z259.11-M92 (R2003) wherever possible, as long as this will not increase the fall distance and allow the worker can hit an obstacle or a lower level.

Another method would be to use a short lanyard that would not allow more than 2 foot free fall.

Note: every precaution should be taken to reduce the free fall as much as possible at all times

A FALL-ARREST SYSTEM

- Must include a CSA-approved full body harness; CSA 259.10-06 (R2010)
- Shock absorbing lanyard conforming to CSA Z259.11-M92 (R2003)
- Safety lanyard conforming to CSA Z259.11-05 (R2010). The rope must be adjusted in such a way not to allow free-fall of more than 4 feet (1, 2 meters).
- NOTE: sharp edges must be protected in such a way to avoid damage to the vertical lifelines or lanyards. The user must install protector cushions on all sharp edges. (See fig. 3)

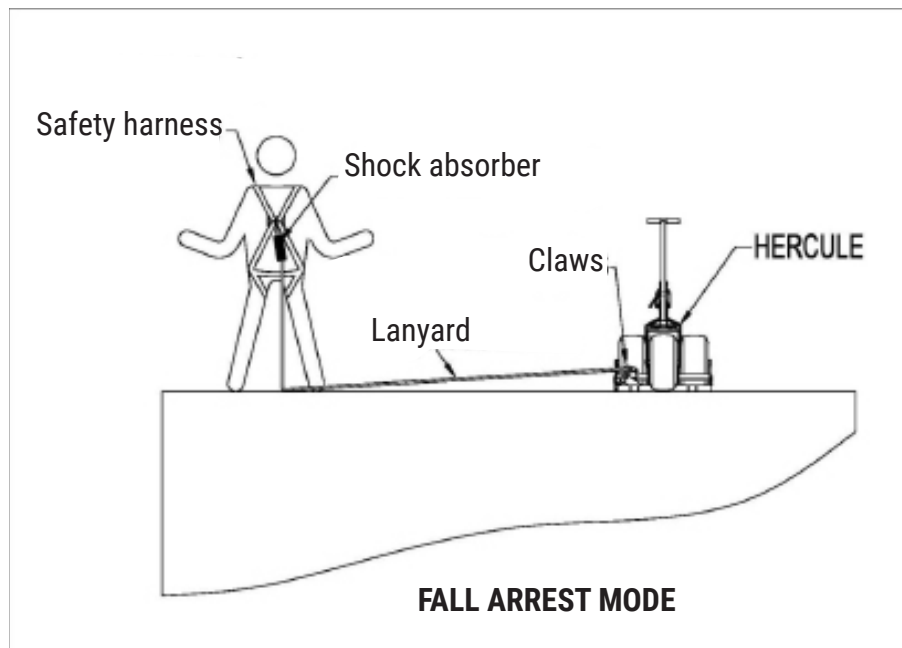

Fig. 3

- NOTE: Snap Hooks Shall be comprised of a hook shaped body with a normally closed keeper or similar arrangement that may be opened to receive an object and when release automatically closes to retain the object. The Self Locking type, required by CSA Z259.1-95 (R2004) shall have a self closing, self locking keeper that remains closed and locked until intentionally unlocked and opened for connection or disconnection only by at least two consecutive and deliberate manual actions .



8. The HERCULES Mobile Anchoring System must only be used by an authorized user. Most regulations require that the employer ensures that an authorised user is a Competent Worker/Person and the installation and use of this equipment must be supervised by a competent person.
9. Positioning on the roof. The HERCULES Mobile Anchoring System must be placed parallel to the edge of the roof at a minimum distance of 9 feet (2,75 meters) in such a way that the teeth on the yellow pivot arms are on the same side as the users when in fall protection mode. Once the HERCULES Mobile Anchoring System is in place, the wheels must be lifted with the use of the built-in jacks at each end of the machine. Once the wheels are off the ground and the HERCULES Mobile Anchoring System rests on the roof, the system is ready to use. The HERCULES Mobile Anchoring System must be placed vis-à-vis the workplace and it must be moved as required to in such a way to avoid a pendulum effect in case of a fall. (See fig. 4)

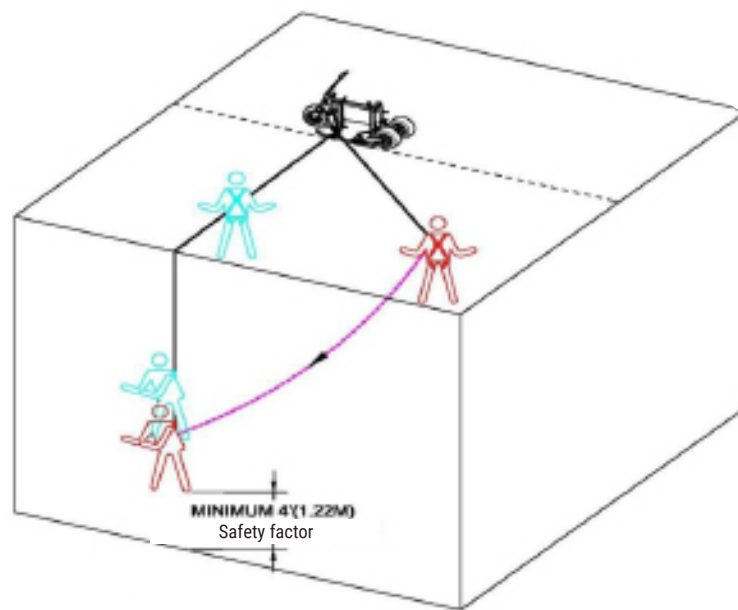

Fig. 4

USE

PRELIMINARY VERIFICATION

Before lifting the HERCULES Mobile Anchoring System onto the roof, the user must insure the structure is able to sustain a static load of 1000 pounds (454 kg) + the weight of the users and their tools. Moreover, it is necessary to make sure the HERCULES Mobile Anchoring System is set up at least 9 feet (2.75 meters) from the edge of the roof.

CALCULATIONS

All calculations must be made before the HERCULES Mobile Anchoring System is set on the roof. These calculations will help determine if the HERCULES Mobile Anchoring System can be used in a fall arrest mode or if it will have to be used in travel restraint mode do to a lack of minimum height. The work area, the distance from the roof edge and any angle at which the users will work also need to be predetermined.



POSITIONING ON THE ROOF

The HERCULES Mobile Anchoring System must be placed parallel to the edge of the roof at a minimum distance of 9 feet (2,75 meters) so that when used in Fall Arrest Mode the teeth on the yellow pivot arms are on the same side as the users. Once the HERCULES Mobile Anchoring System is in place, the wheels must be lifted with the use of the built-in jacks at each end of the machine. Once the wheels are off the ground and the HERCULES Mobile Anchoring System rests on the roof, the system is ready to use. The HERCULES Mobile Anchoring System must be placed vis-à-vis the workplace and it must follow the users as they go along in such a way to avoid the pendulum effect in case of a fall.

For use in travel restraint mode, the user must anchor his safety lanyard to one of the blue rings located on the vertical post. (See figure 5)

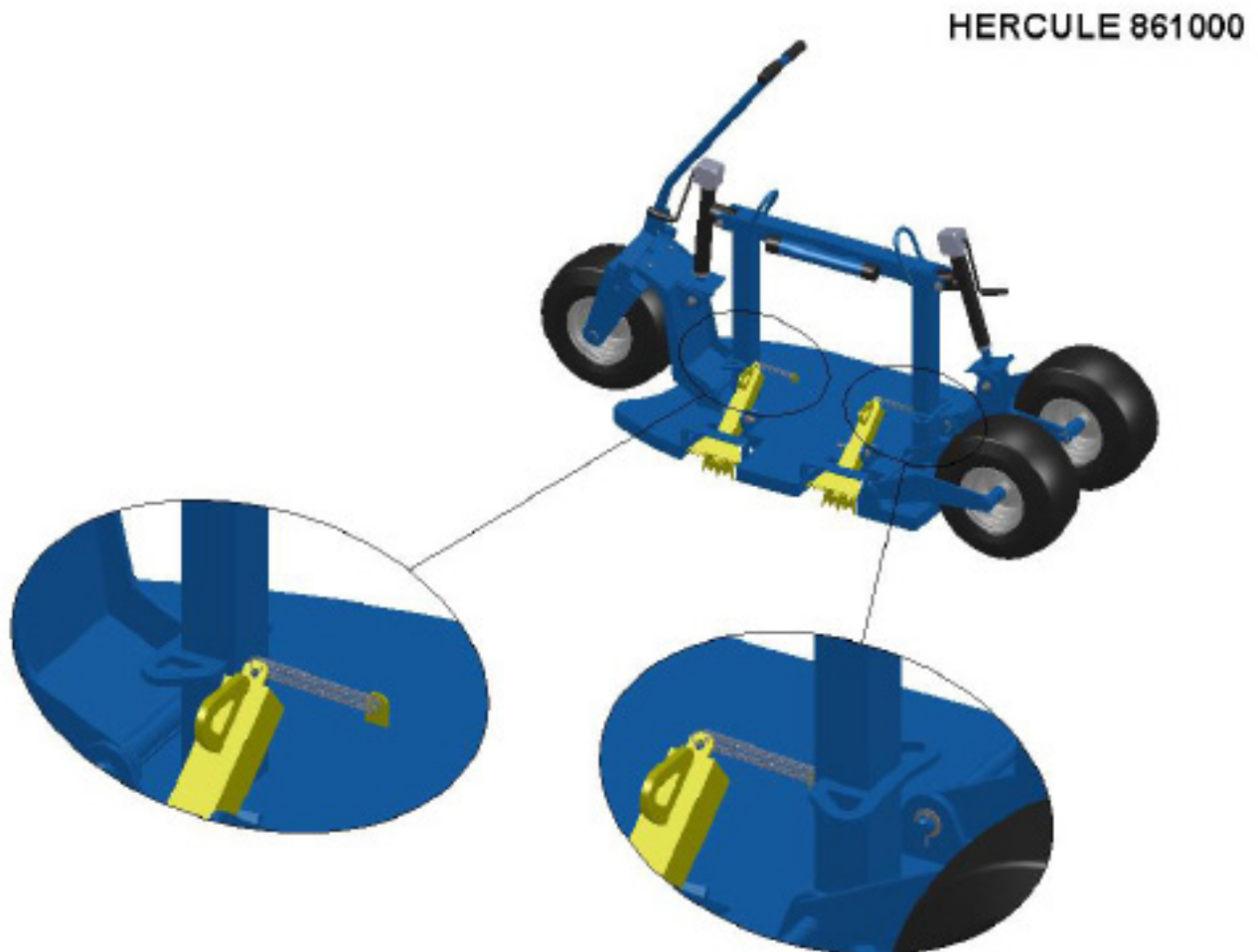

Fig.5



For use in fall arrest mode, the user must anchor his safety lanyard to one of the yellow pivot arms. No more than one user per yellow pivot arm. (See figure 6)

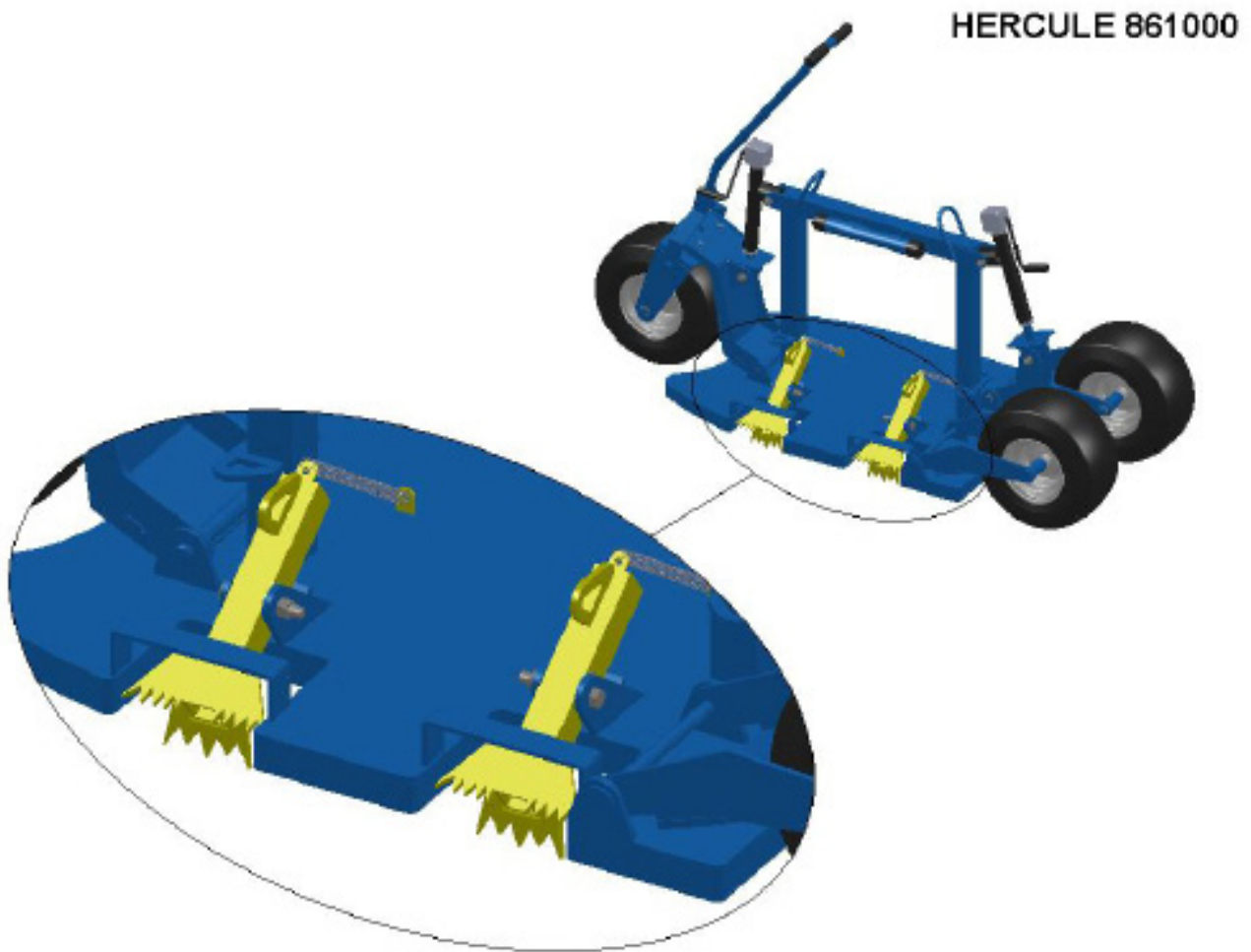

Fig.6



TRAINING

All Provinces and States have specific training requirements for all users of fall protection equipment. This manual is to be used as a tool for training and in no way replaces training of workers by qualified persons

It is the responsibility of every employer to ensure that their workers to understand how to safely use this equipment. A complete training program will include a theoretical section and a practical section. Each user must be taught the right way to use the HERCULES Mobile Anchoring System (conditions of use, installation method, distinction between travel restraint and fall arrest, require material depending on the mode used, etc.) Training must also include how to complete a pre use inspection of the HERCULES Mobile Anchoring System. Workers must also be instructed on the correct way to calculate the total distance of a fall and calculate the minimum safe distance they will require for their anchorage and equipment they will be using.

INSPECTION, MAINTENANCE, STORAGE

INSPECTION

The HERCULES Mobile Anchoring System must be inspected before every use. The user must use the verification list in section 8 of the present manual. The inspection aims to identify elements that could affect the efficiency of the HERCULES Mobile Anchoring System (missing or damage parts, corrosion, etc.).

The HERCULES Mobile Anchoring System must be inspected at least once a year by the manufacturer or a Competent/Qualified person. In the case of a fall, the HERCULES Mobile Anchoring System must be verified by the manufacturer before it can be used again. This inspection aims to insure the HERCULES Mobile Anchoring System always adheres to the necessary specifications for its smooth and safe functioning.

MAINTENANCE

The HERCULES Mobile Anchoring System does not require any particular maintenance, other than greasing of the wheel bearings and checking tire pressure. However, if the user notes an abnormality at the inspection prior to its use, the HERCULES Mobile Anchoring System must be removed from use and tagged: "Dangerous – Out of Use". The required repair must be made before putting back into service. Any part used for a repair must guarantee a safety level at least equal to the one of the original part. Any repairs that are integral to the safety of the equipment and its users must be approved by the manufacturer

STORAGE

The HERCULES Mobile Anchoring System must be stored in such a way as to not be exposed to shocks, bad weather, corrosive substances or any other element that could damage it. Moreover, it is recommended not to store the HERCULES Mobile Anchoring System at height due to its weight and the risks of injury.



LIFTING

The HERCULES Mobile Anchoring System includes two lifting rings located on top of its chassis. These rings are to be used only for slings and lifting hooks. At no time are these rings to be used as an anchor point for the users. (See figure7)

You must always insure that the lifting and hooking accessories used are in good condition and that they have the load capacity required to lift the HERCULES Mobile Anchoring System.

Never use the eyelets yellow pivot arms or the anchoring rings for travel restraint to lift the HERCULES Mobile Anchoring System.

IT IS STRICTLY FORBIDDEN TO USE THE BLUE RINGS LOCATED ABOVE THE DEVICE AS AN ANCHOR POINT. (These rings are only to be used for lifting the equipment (See figure 7)

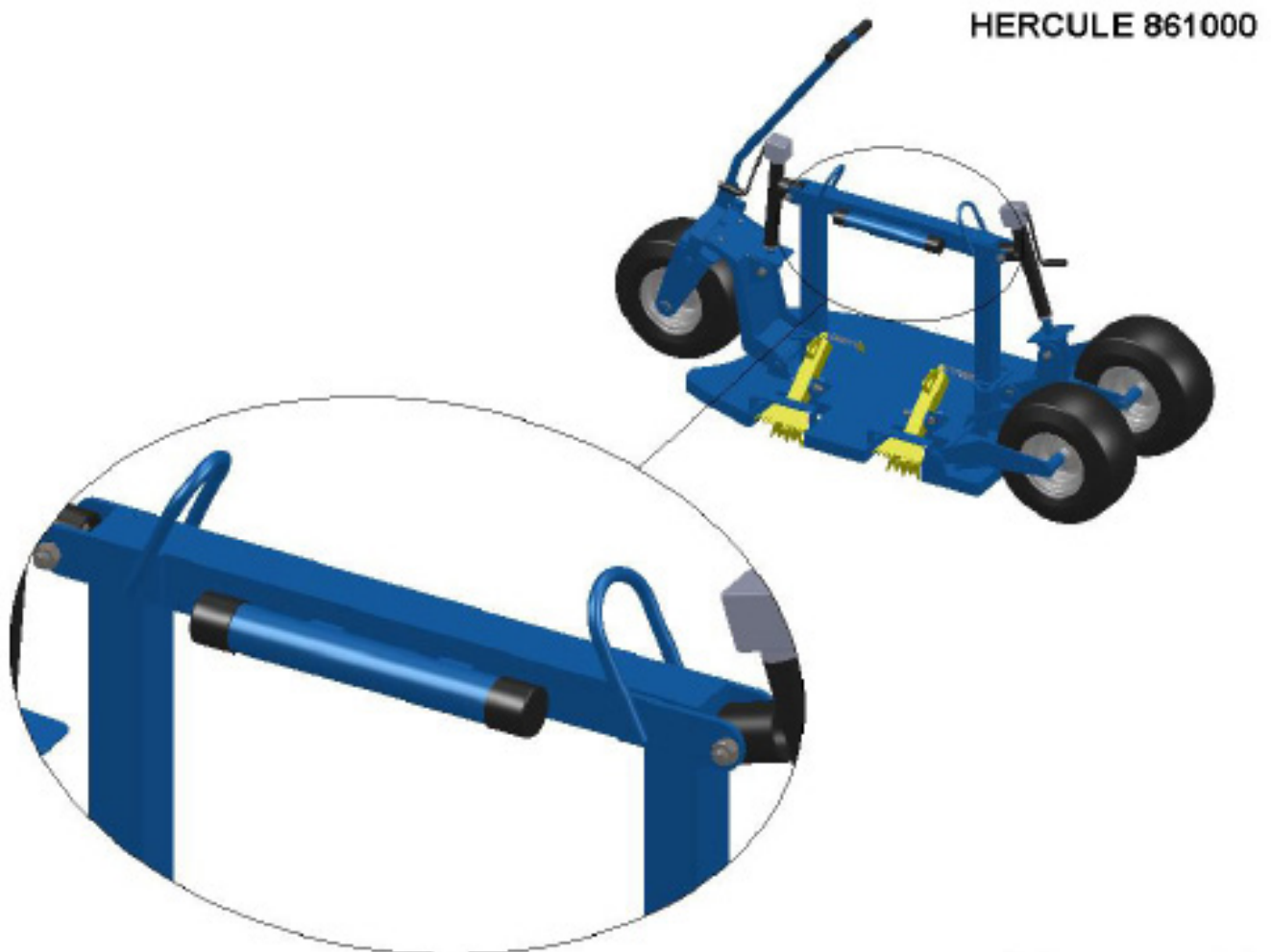

Fig.7



STICKERS

At the time of visual inspection, it is necessary to verify the presence of the following stickers. If they are damaged, missing or unreadable, please contact GRIZZLY/ASE to obtain replacement stickers.



PRE-USE AND INSPECTION FORM FOR GRIZZLY 861 000 HERCULES MOBILE ANCHORING SYSTEM

Please make copies of this form and complete it before each use in two copies. A completed form must follow the Hercules mobile anchoring system on site and the other is for your records. Users must review this form prior to use.

SERIAL #: _____ INSPECTION DATE: _____

ADDRESS OR PROJECT NAME: _____

HEIGHT BETWEEN THE PLACE THE HERCULES WILL BE POSITIONED AND THE GROUND OR ANY OBSTACLE: _____

Travel restraint is always preferred over fall arrest

Does this project allow the use of the mobile anchoring system in fall arrest mode? Yes No

Comment : _____

Inspection :

	Conform			Conform	
	Yes	No		Yes	No
Welds			General condition		
Anchors			Lifting rings		
Pivot arms			Stickers		
Jacks			Corrosion		
Wheels			Other		

If non-compliance is noted, please label «Dangerous - Out of Order» and have unit repaired before reusing.

Signed : _____ Name (bloc letters) : _____

